



Refrigerated
case

BASIA

DEVICE SERIES ASSEMBLY INSTRUCTIONS

29.07.2019

Address:
Stary Wiśnicz 289
32-720 Nowy Wiśnicz, Poland

Tel.: +48 14/662 19 10
fax: +48 14/662 19 12

e-mail: info@igloo.pl
www.igloo.pl

ORIGINAL INSTRUCTIONS

29.07.2019

READ CAREFULLY BEFORE USE,
KEEP FOR USE IN THE FUTURE

DEVICE SERIES ASSEMBLY INSTRUCTIONS	VERSION				PAGE: 1/13
	Lfd.Nr..	DATE	Lfd.Nr..	DATE	
TYPE: BASIA					
DOCUMENT NO:	A		D		
NO: 0	B		E		DATE of 1st issue:
SPIS TREŚCI	C		F		29.07.2019

NO	CHAPTER	PAGE NO	VER-SION STATUS	DOCUMENTATION NO
0	CONTENTS	1	-	x
1	Device unpacking	2	-	x
2	Preparation of fasteners delivered with devices	2	-	x
3	Preparation of tools necessary for connection of furniture in series	2	-	x
4	Preparation of devices for assembly in series	3	-	x
4.1	Depacking of shelves, screens and tops	3	-	x
4.2	Unscrewing an intake	3	-	x
4.3	Pulling fans	3	-	x
4.4	Turning wind braces	3	-	x
5	Making seals delivered with devices	4	-	x
6	Setting combined modules (single units)	4	-	x
7	Setting of devices so that all assembly holes are in common axes	5	-	x
8	Move modules to each other at approx. 5 mm	5	-	x
9	Connecting devices with each other via delivered fasteners	5	-	x
10	Levelling of device set via level lines	5	-	x
11	Removal of insulation under working top	6	-	x
12	Connecting devices with each other via delivered fasteners	6	-	x
13	Putting insulation under working top	6	-	x
14	Screwing lamp rack	6	-	x
15	Screwing lamp profiles	7	-	x
16	Assembly of side glass panels	7	-	x
17	Screwing glass sides to lamp profile	7	-	x
18	Assembly of fans	8	-	x
19	Turning on an intake	8	-	x
20	Assembly of granite tops	9	-	x
20.1	Placing tops on device set	9	-	x
20.2	Gluing of tops	9	-	x
20.3	Sealing of tops	9	-	x
20.4	Removal of a double-sided tape from night-time covers	9	-	x
20.5	Putting glue on night-time cover	10	-	x
20.6	Putting a cover on a granite top for night covers	10	-	x
21	Making sealing on module connections	11	-	x
22	Arrangement of device shelves	11	-	x
23	Arrangement of screens	12	-	x
24	Assembly of partitions (if any)	12	-	x
25	Assembly of a shelf for customer (if any)	12	-	x
26	Assembly of night covers	12	-	x
27	After assembling the devices in series before the startup, connect all connectors between modules	13	-	x
28	Connecting devices to the cooling and electrical systems - by authorized persons appointed by the recipient	13	-	x
29	Placing silicone on front glass panel profile	13	-	x
30	Assembly of front glass panel	13	-	x

KEY:

-	First issue
A, B, ...	Version index
X	Chapter No as per the Documentation No

DEVICE SERIES ASSEMBLY INSTRUCTIONS	VERSION				PAGE: 2/13
	Lfd.Nr..	DATE	Lfd.Nr..	DATE	
TYPE: BASIA	A		D		DATE of 1st issue: 29.07.2019
DOCUMENT NO:	B		E		
NO: 1,2,3	C		F		



1

Device unpacking



2

Preparation of fasteners delivered with devices



3

Preparation of tools necessary for connection of furniture in series

- 2x open ended spanner no 13
- Allen wrench no 4
- Screwdriver
- 2 level lines, long one 2 m and short one - approx. 0.5 m

DEVICE SERIES ASSEMBLY INSTRUCTIONS	VERSION				PAGE: 3/13
	Lfd.Nr..	DATE	Lfd.Nr..	DATE	
TYPE: BASIA	A		D		DATE of 1st issue: 29.07.2019
DOCUMENT NO:	B		E		
NO: 4.4.1,4.2,4.3,4.4	C		F		

4

PREPARATION OF DEVICES FOR ASSEMBLY IN SERIES

- Arrange the devices connected in series according to their target configuration, keeping the distance at the connection point of 20 cm.
- Remove all delivered packed components such as lamps, glass sides, shelves, etc. from the inside of the device body.
- Unscrew legs by slightly tilting the device from the front, remove the base board and then screw in the legs again. Remove the base board from the back in the same manner



4.1

Depacking of shelves, glass panels, screens and tops



4.2

Unscrewing an intake

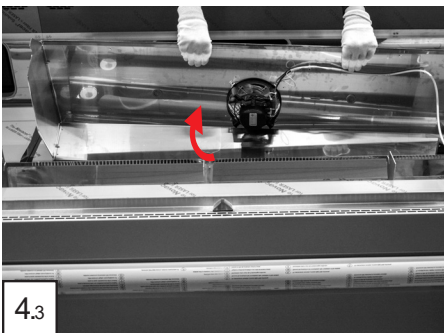

4.3

Pulling of fans

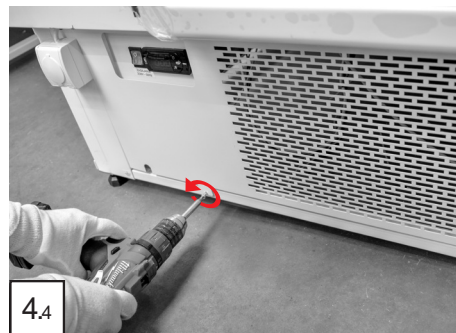

4.4

Turning wind braces

DEVICE SERIES ASSEMBLY INSTRUCTIONS	VERSION				PAGE: 4/13
	Lfd.Nr..	DATE	Lfd.Nr..	DATE	
TYPE: BASIA B	A		D		DATE of 1st issue: 29.07.2019
DOCUMENT NO:	B		E		
NO: 5,6	C		F		

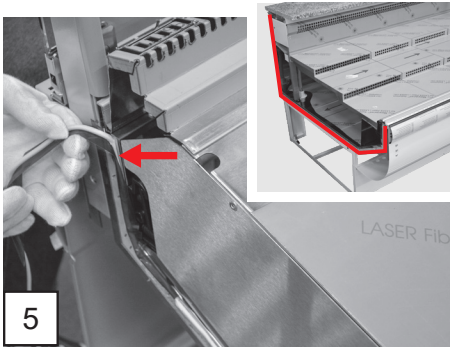

5

Making seals delivered with devices

To seal the space between the devices, the sealing compound of putty is formed in rollers arranged on the belt. Seals are placed on one body only

- Tear one roller off the tape gently, remove the paper cover and then stick it in the place shown in the picture. Sticking is done by pressing the mass with fingers to the body of the device through the tape. Then tear off the tape. Sealing must be applied on the sheet to the side flange of the sheet only forming the inside of the body. Do not place sealing on wooden elements of body reinforcements

ATTENTION! Imprecise seals cause that the device does not remain leakproof during operation!

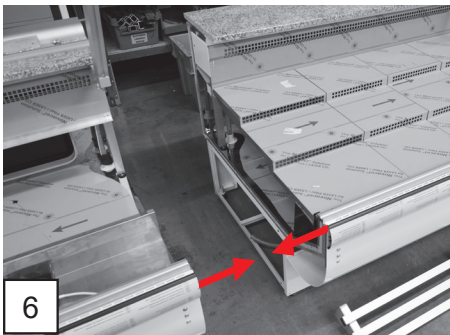

6

Setting combined modules (single units)

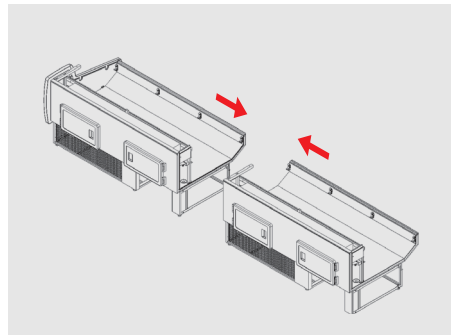

DEVICE SERIES ASSEMBLY INSTRUCTIONS	VERSION				PAGE: 5/13
	Lfd.Nr.	DATE	Lfd.Nr.	DATE	
TYPE: BASIA B	A		D		DATE of 1st issue: 29.07.2019
DOCUMENT NO:	B		E		
NO: 7,8,9,10	C		F		

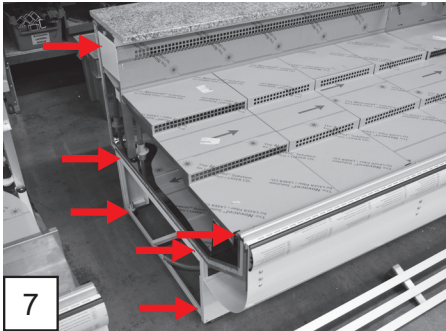

7
Setting of devices so that all assembly holes are in common axes

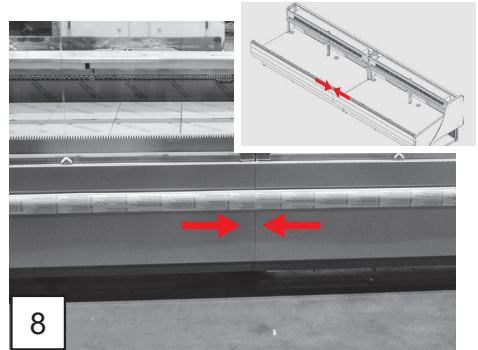

8
Move modules to each other at approx. 5 mm



9
Connecting devices with each other via delivered fasteners

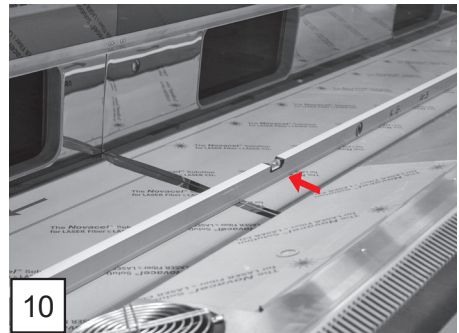

10
Levelling of device set via level lines

- At the place of connection, adjust height from the front and back, screwing on or out legs in the base.
- Adjust every module via level line at places shown in fig.

DEVICE SERIES ASSEMBLY INSTRUCTIONS	VERSION				PAGE:6/13
	Lfd.Nr.	DATE	Lfd.Nr.	DATE	
TYPE: BASIA B	A		D		DATE of 1st issue: 29.07.2019
DOCUMENT NO:	B		E		
NO: 11,12,13,14	C		F		



11 Removal of insulation under the working top

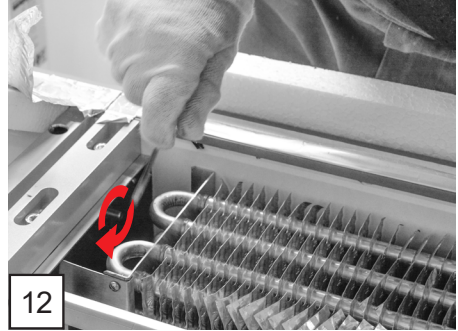

12 Screw devices together with delivered fasteners



13 Putting insulation under working top



14 Screwing lamp rack

DEVICE SERIES ASSEMBLY INSTRUCTIONS	VERSION				PAGE: 710
	Lfd.Nr..	DATE	Lfd.Nr..	DATE	
TYPE: BASIA B	A		D		DATE of 1st issue: 29.07.2019
DOCUMENT NO:	B		E		
NO: 15,16,17	C		F		



15

Screwing lamp profiles

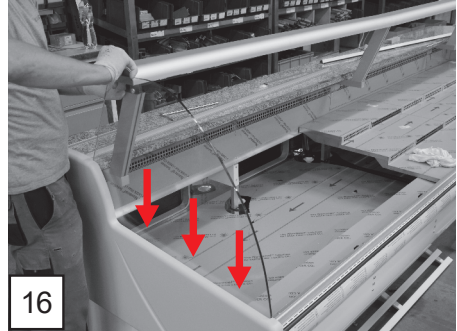

16

Assembly of side glass panels

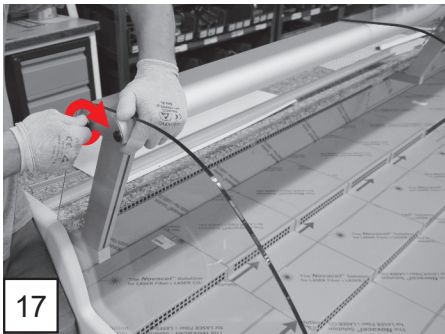

17

Screwing glass sides to lamp profile

DEVICE SERIES ASSEMBLY INSTRUCTIONS	VERSION				PAGE: 8/13
	Lfd.Nr.	DATE	Lfd.Nr.	DATE	
TYPE: BASIA B	A		D		DATE of 1st issue: 29.07.2019
DOCUMENT NO:	B		E		
NO: 18,19	C		F		

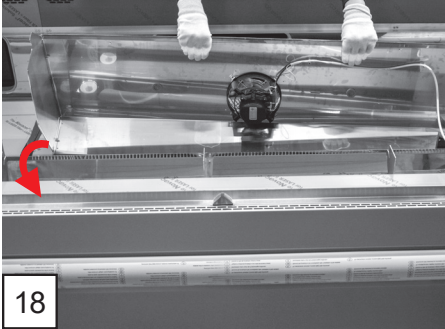

18

Assembly of fans



19

Turning on an intake

DEVICE SERIES ASSEMBLY INSTRUCTIONS	VERSION				PAGE: 9/13
	Lfd.Nr.	DATE	Lfd.Nr.	DATE	
TYPE: BASIA B	A		D		DATE of 1st issue: 29.07.2019
DOCUMENT NO:	B		E		
NO: 20, 20.1, 20.2, 20.3, 20.4	C		F		

20

Assembly of granite tops For metal tops – no need



20.1

Placing tops on device set

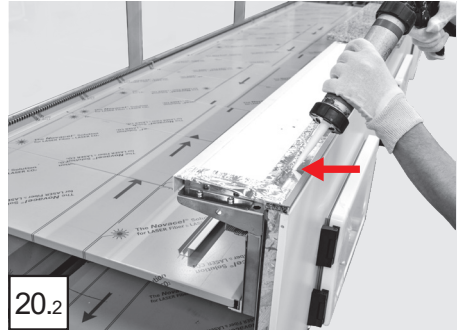

20.2

Gluing of tops



20.3

Sealing of tops

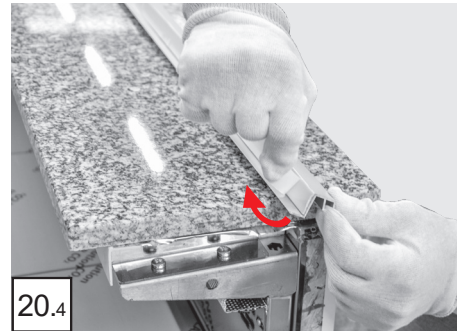

20.4

Removal of a double-sided tape from night-time covers

DEVICE SERIES ASSEMBLY INSTRUCTIONS	VERSION				PAGE: 10/13
	Lfd.Nr..	DATE	Lfd.Nr..	DATE	
TYPE: BASIA	A		D		DATE of 1st issue: 29.07.2019
DOCUMENT NO:	B		E		
NO: 20.5, 20.6	C		F		

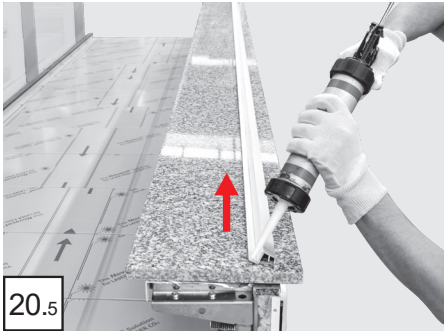

Putting glue on night-time cover

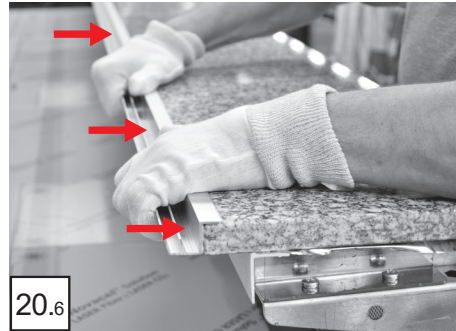

Putting a cover on a granite top for night covers

DEVICE SERIES ASSEMBLY INSTRUCTIONS	VERSION				PAGE: 11/13
	TYPE: BASIA PG	Lfd.Nr..	DATE	Lfd.Nr..	
DOCUMENT NO:	A		D		
NO: 21.22	B		E		
	C		F		DATE of 1st issue: 29.07.2019

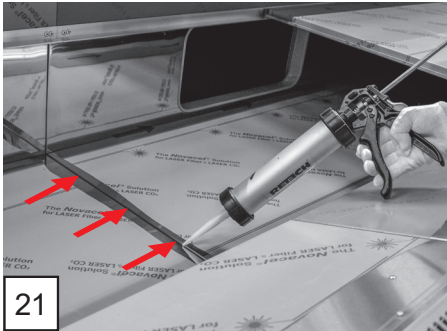

21

Making sealing on module connections

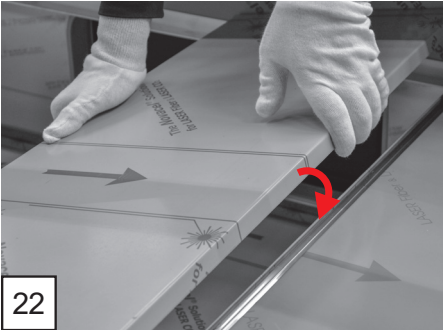

22

Arrangement of device shelves

The exhibition shelves consist of three types of components:

- Exhibition shelf 305 [detail 23]
- Additional part [detail 24]
- Connector [detail 25]

- Arrangement of shelves from the right side.
- Put the shelf 305 [detail 26] first. Next, place shelves 305 as the so-called fin of the previous shelf [detail 27]. Set an appropriate addition to the module length as the last in a given module.
- Place a connector [detail 28] under the addition of previous module [detail 29] and shelf 305 of the next module 22 [detail 30]

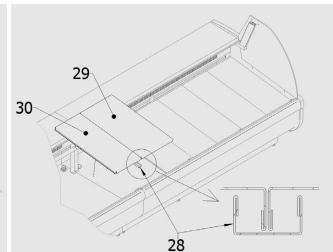
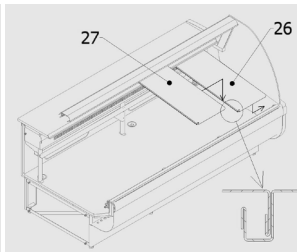
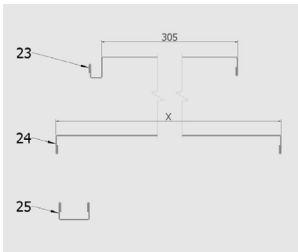

DEVICE SERIES ASSEMBLY INSTRUCTIONS	VERSION				PAGE: 12/13
	Lfd.Nr.	DATE	Lfd.Nr.	DATE	
TYPE: BASIA	A		D		DATE of 1st issue: 29.07.2019
DOCUMENT NO:	B		E		
NO: 23,24,25,26	C		F		



23

Arrangement of screens



24

Assembly of partitions (if any)



25

Assembly of a shelf for customer (if any)

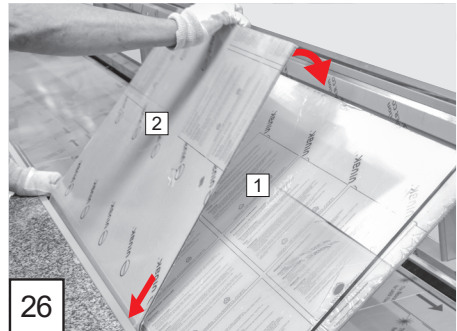

26

Assembly of night covers

1. Night cover lower (shorter) - assembled as first one
2. Night cover upper (longer) – assembles as second one

DEVICE SERIES ASSEMBLY INSTRUCTIONS	VERSION				PAGE: 13/13
	TYPE: BASIA	Lfd.Nr..	DATE	Lfd.Nr..	
DOCUMENT NO:	A		D		
NO: 37,38	B		E		
	C		F		DATE of 1st issue: 29.07.2019

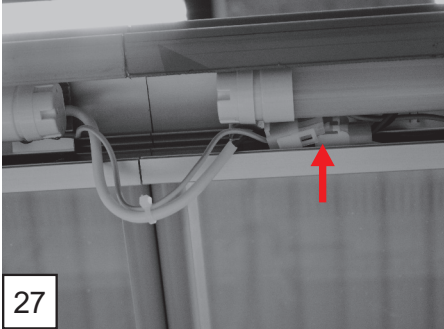

27

After assembling the devices in series before the startup, connect all connectors between modules

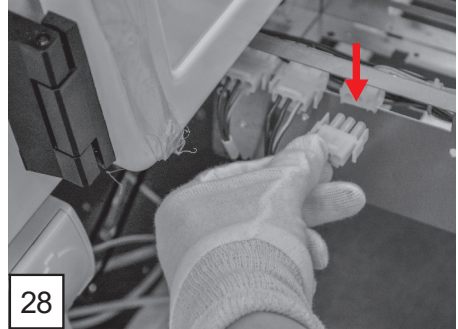

28

Connecting devices to the cooling and electrical systems - by authorized persons appointed by the recipient

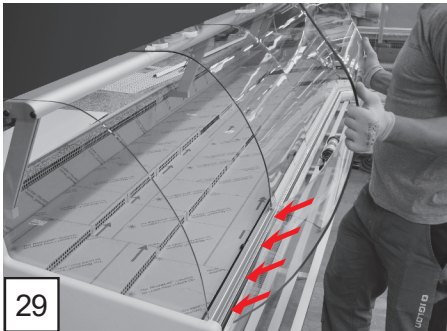

29

Assembly of front glass panel

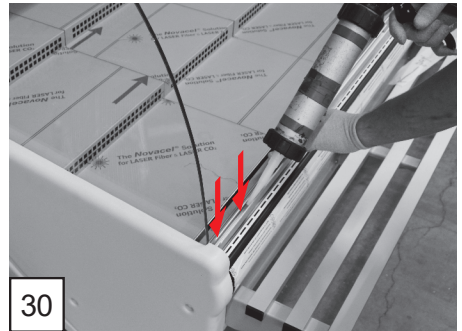

30

Placing silicone on front glass panel profile



Issue - July 2019

Address:
Stary Wiśnicz 289
32-720 Nowy Wiśnicz, Poland

Tel.: +48 14/662 19 10
fax: +48 14/662 19 12

e-mail: info@igloo.pl
www.igloo.pl